

CONTAMINATION CONTROL SOLUTIONS

MOBILE FILTRATION UNITS



PASSION TO PERFORM





A WORLDWIDE LEADER IN THE FIELD OF HYDRAULIC FILTRATION EQUIPMENT.

Our company started life in 1964, when Bruno Pasotto decided to attempt to cater for the requests of a market still to be fully explored, with the study, design, development, production and marketing of a vast range of filters for hydraulic equipment, capable of satisfying the needs of manufacturers in all sectors. The quality of our products, our extreme competitiveness compared with major international producers and our constant activities of research, design and development has made us a worldwide leader in the field of hydraulic circuit filtering. Present for 50 years in the market, we have played a truly decisive role in defining our sector, and by now we are a group capable of controlling our entire chain of production, monitoring all manufacturing processes to guarantee superior quality standards and to provide concrete solutions for the rapidly evolving needs of customers and the market.

MARKET LEADER



Our work is based on a skillful interaction between advanced technology and fine workmanship, **customizing products according to specific market requests**, focusing strongly on innovation and quality, and following every step in the manufacturing of both standard and special products, fully respecting customer expectations.



Our customer-oriented philosophy, which enables us to satisfy all customer requests **rapidly and with personalized products**, makes us a **dynamic and flexible enterprise**. The possibility of constantly controlling and monitoring the entire production process is essential to allow us to guarantee the quality of our products.

WORLDWIDE PRESENCE

Our foreign Branches enable us to offer a diversified range of products that allow us to successfully face the aggressive challenge of international competition, and also to maintain a stable presence at a local level.

The Group boasts **8 business branches**



TECHNOLOGY

Our constant **quest for excellence in quality and technological innovation** allows us to offer only the best solutions and services for applications in many fields, including general industry, test rigs, lubrication, heavy engineering, renewable energies, naval engineering, offshore engineering, aviation systems, emerging technologies and mobile plant (i.e. tractors, excavators, concrete pumps, platforms).



AND PRODUCTION

Our high level of technological expertise means **we can rely entirely on our own resources, without resorting to external providers.** This in turn enables us to satisfy a growing number of customer requests, also exploiting our constantly updated range of machines and equipment, featuring **fully-automated workstations** capable of **24-hour production.**

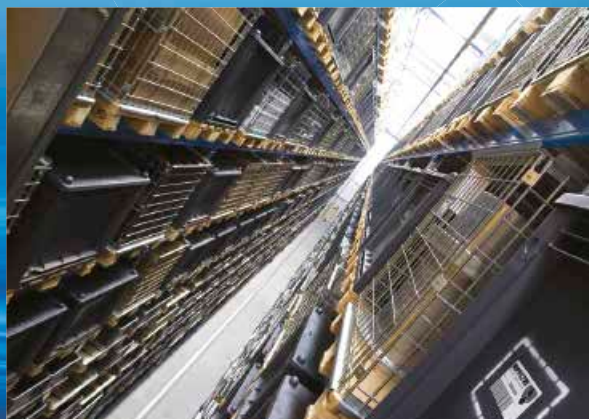



SUCTION FILTERS

Flow rates
up to 875 l/min

- Mounting:
- Tank immersed
 - In-Line
 - In tank with shut off valve
 - In tank with flooded suction

RETURN FILTERS

Flow rates
up to 3000 l/min

- Pressure
up to 20 bar
- Mounting:
- In-Line
 - Tank top
 - In single and duplex designs

RETURN / SUCTION FILTERS

Flow rates
up to 300 l/min

- Pressure
up to 80 bar
- Mounting:
- In-Line
 - Tank top

SPIN-ON FILTERS

Flow rates
up to 365 l/min

- Pressure
up to 35 bar
- Mounting:
- In-Line
 - Tank top

LOW & MEDIUM PRESSURE FILTERS

Flow rates
up to 3000 l/min

- Pressure
up to 80 bar
- Mounting:
- In-Line
 - Parallel manifold version
 - In single and duplex designs

HIGH PRESSURE FILTERS

Flow rates
up to 750 l/min

- Pressure from 110 bar
up to 560 bar
- Mounting:
- In-Line
 - Manifold
 - In single and duplex designs

PRODUCT RANGE

MP Filtri can offer a vast and articulated range of products for the global market, suitable for all industrial sectors using hydraulic equipment.

This includes filters (suction, return, return/suction, spin-on, pressure, stainless steel pressure) and structural components (motor/pump bell-housings, transmission couplings, damping rings, foot brackets, aluminium tanks, cleaning covers).

We can provide all the skills and solutions required by the modern hydraulics industry to monitor contamination levels and other fluid conditions.

Mobile filtration units and a full range of accessories allow us to supply everything necessary for a complete service in the hydraulic circuits.



STAINLESS STEEL HIGH PRESSURE FILTERS

Flow rates up to 125 l/min
Pressure from 320 bar
up to 1000 bar

Mounting:

- In-Line
- Manifold
- In single and duplex designs

CONTAMINATION MONITORING PRODUCTS

- Online, in-line particle counters
- Off-line bottle sampling products
- Fully calibrated using relevant ISO standards
- A wide range of variants to support fluid types and communication protocols

MOBILE FILTRATION UNITS

Flow rates from 15 l/min
up to 200 l/min

POWER TRANSMISSION PRODUCTS

- Aluminium bell-housings for motors from 0.12 kW to 400 kW
- Couplings in Aluminium Cast Iron - Steel
- Damping rings
- Foot bracket
- Aluminium tanks
- Cleaning covers

ACCESSORIES

- Oil filler and air breather plugs
- Optical and electrical level gauges
- Pressure gauge valve selectors
- Pipe fixing brackets
- Pressure gauges

CONTAMINATION CONTROL SOLUTIONS



...because contamination costs!

1 page		INTRODUCTION
1	COMPANY	
6	PRODUCT RANGE	
11	CONTAMINATION MANAGEMENT	

18 page		AUTOMATIC PARTICLE COUNTERS
21	LPA3	Portable Particle Counter
27	LPA2	Twin Laser Particle Analyser
33	CML2	Compact Twin Laser Contamination Monitor
39	ICM 2.0	In-line Contamination Monitor
45	AZ2	ATEX Fluid Contamination Monitors
51	ICU	In-line Contamination Monitoring Unit
57	ACMU	Auxiliary Contamination Monitoring Unit
63	BS110 & BS500	Bottle Samplers
72	HOW SAMPLING	
75	VPAF100	Patch test kit
78	FLUID COMPATIBILITY CHARTS	
81	SPARE PARTS LIST	
83	ACCESSORIES	

92 page		MOBILE FILTRATION UNITS
95	UFM 015	Mobile filtration unit 15 l/min flow rate
101	UFM 041	Mobile filtration unit 34 l/min flow rate
107	UFM 051	Mobile filtration unit 50 l/min flow rate
113	UFM 091	Mobile filtration unit 90 l/min flow rate
119	UFM 181	Mobile filtration unit 180 l/min flow rate
125	UFM 919	Mobile filtration unit 90 l/min and 180 l/min flow rate
131	FTU 080	Fluid transfer unit 15 l/min flow rate



Contamination management

INDEX

	Page
① HYDRAULIC FLUIDS	12
② FLUIDS CONTAMINATION	12
③ EFFECTS OF CONTAMINATION ON HYDRAULIC COMPONENTS	12
④ MEASURING THE SOLID CONTAMINATION LEVEL	13
⑤ RECOMMENDED CONTAMINATION CLASSES	16
⑥ WATER IN HYDRAULIC AND LUBRICATING FLUIDS	16

1 HYDRAULIC FLUIDS

The fluid is the vector that transmits power, energy within an oleodynamic circuit. In addition to transmitting energy through the circuit, it also performs additional functions such as lubrication, protection and cooling of the surfaces.

The classification of fluids used in hydraulic systems is coded in many regulatory references, different Standards.

The most popular classification criterion divides them into the following families:

- MINERAL OILS

Commonly used oil deriving fluids.

- FIRE RESISTANT FLUIDS

Fluids with intrinsic characteristics of incombustibility or high flash point.

- SYNTHETIC FLUIDS

Modified chemical products to obtain specific optimized features.

- ECOLOGICAL FLUIDS

Synthetic or vegetable origin fluids with high biodegradability characteristics.

The choice of fluid for an hydraulic system must take into account several parameters.

These parameters can adversely affect the performance of an hydraulic system, causing delay in the controls, pump cavitation, excessive absorption, excessive temperature rise, efficiency reduction, increased drainage, wear, jam/block or air intake in the plant.

The main properties that characterize hydraulic fluids and affect their choice are:

- DYNAMIC VISCOSITY

It identifies the fluid's resistance to sliding due to the impact of the particles forming it.

- CINEMATIC VISCOSITY

It is a widespread formal dimension in the hydraulic field.

It is calculated with the ratio between the dynamic viscosity and the fluid density.

Cinematic viscosity varies with temperature and pressure variations.

- VISCOSITY INDEX

This value expresses the ability of a fluid to maintain viscosity when the temperature changes.

A high viscosity index indicates the fluid's ability to limit viscosity variations by varying the temperature.

- FILTERABILITY INDEX

It is the value that indicates the ability of a fluid to cross the filter materials. A low filterability index could cause premature clogging of the filter material.

- WORKING TEMPERATURE

Working temperature affects the fundamental characteristics of the fluid. As already seen, some fluid characteristics, such as cinematic viscosity, vary with the temperature variation.

When choosing a hydraulic oil, must therefore be taken into account of the environmental conditions in which the machine will operate.

- COMPRESSIBILITY MODULE

Every fluid subjected to a pressure contracts, increasing its density.

The compressibility module identifies the increase in pressure required to cause a corresponding increase in density.

- HYDROLYTIC STABILITY

It is the characteristic that prevents galvanic pairs that can cause wear in the plant/system.

- ANTIOXIDANT STABILITY AND WEAR PROTECTION

These features translate into the capacity of a hydraulic oil to avoid corrosion of metal elements inside the system.

- HEAT TRANSFER CAPACITY

It is the characteristic that indicates the capacity of hydraulic oil to exchange heat with the surfaces and then cool them.

2 FLUID CONTAMINATION

Whatever the nature and properties of fluids, they are inevitably subject to contamination. Fluid contamination can have two origins:

- INITIAL CONTAMINATION

Caused by the introduction of contaminated fluid into the circuit, or by incorrect storage, transport or transfer operations.

- PROGRESSIVE CONTAMINATION

Caused by factors related to the operation of the system, such as metal surface wear, sealing wear, oxidation or degradation of the fluid, the introduction of contaminants during maintenance, corrosion due to chemical or electrochemical action between fluid and components, cavitation. The contamination of hydraulic systems can be of different nature:

- SOLID CONTAMINATION

For example rust, slag, metal particles, fibers, rubber particles, paint particles or additives

- LIQUID CONTAMINATION

For example, the presence of water due to condensation or external infiltration or acids

- GASEOUS CONTAMINATION

For example, the presence of air due to inadequate oil level in the tank, drainage in suction ducts, incorrect sizing of tubes or tanks.

3 EFFECTS OF CONTAMINATION ON HYDRAULIC COMPONENTS

Solid contamination is recognized as the main cause of malfunction, failure and early degradation in hydraulic systems. It is impossible to delete it completely, but it can be effectively controlled by appropriate devices.

CONTAMINATION IN PRESENCE OF LARGE TOLERANCES



CONTAMINATION IN PRESENCE OF NARROW TOLERANCES



Solid contamination mainly causes surface damage and component wear.

- SURFACE EROSION
Cause of leakage through mechanical seals, reduction of system performance, variation in adjustment of control components, failures.
- ADHESION OF MOVING PARTS
Cause of failure due to lack of lubrication.
- DAMAGES DUE TO FATIGUE
Cause of breakdowns and components breakdown.

- MODIFICATION OF FLUID PROPERTIES
(COMPRESSIBILITY MODULE, DENSITY, VISCOSITY)
Cause of system's reduction of efficiency and of control.
It is easy to understand how a system without proper contamination management is subject to higher costs than a system that is provided.
- MAINTENANCE
Maintenance activities, spare parts, machine stop costs
- ENERGY AND EFFICIENCY
Efficiency and performance reduction due to friction, drainage, cavitation.

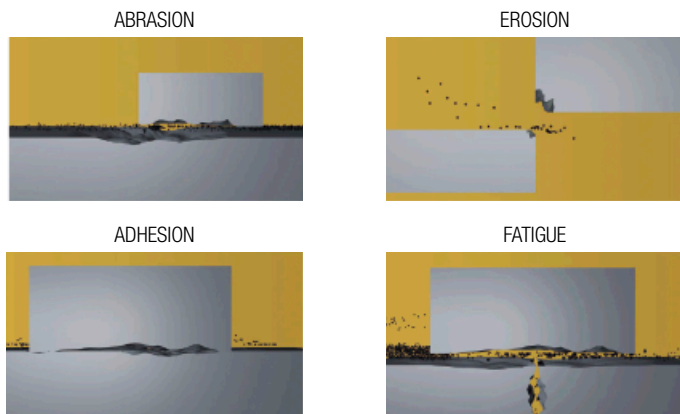

Liquid contamination mainly results in decay of lubrication performance and protection of fluid surfaces.

DISSOLVED WATER

- INCREASING FLUID ACIDITY
Cause of surface corrosion and premature fluid oxidation
- GALVANIC COUPLE AT HIGH TEMPERATURES
Cause of corrosion

FREE WATER - ADDITIONAL EFFECTS

- DECAY OF LUBRICANT PERFORMANCE
Cause of rust and sludge formation, metal corrosion and increased solid contamination
- BATTERY COLONY CREATION
Cause of worsening in the filterability feature
- ICE CREATION AT LOW TEMPERATURES
Cause damage to the surface
- ADDITIVE DEPLETION
Free water retains polar additives

Gaseous contamination mainly results in decay of system performance.

- CUSHION SUSPENSION
Cause of increased noise and cavitation.
- FLUID OXIDATION
Cause of corrosion acceleration of metal parts.

4 MEASURING THE SOLID CONTAMINATION LEVEL

The level of contamination of a system identifies the amount of contaminant contained in a fluid.

This parameter refers to a unit volume of fluid.

The level of contamination may be different at different points in the system. From the information in the previous paragraphs it is also apparent that the level of contamination is heavily influenced by the working conditions of the system, by its working years and by the environmental conditions.

What is the size of the contaminating particles that we must handle in our hydraulic circuit?

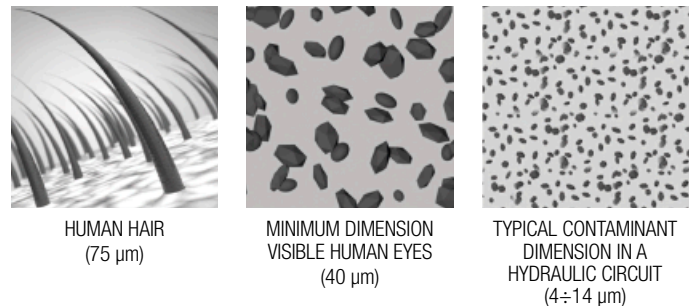

Contamination level analysis is significant only if performed with a uniform and repeatable method, conducted with standard test methods and suitably calibrated equipment.

To this end, ISO has issued a set of standards that allow tests to be conducted and express the measured values in the following ways.

- GRAVIMETRIC LEVEL - ISO 4405

The level of contamination is defined by checking the weight of particles collected by a laboratory membrane. The membrane must be cleaned, dried and desiccated, with fluid and conditions defined by the Standard.

The volume of fluid is filtered through the membrane by using a suitable suction system. The weight of the contaminant is determined by checking the weight of the membrane before and after the fluid filtration.

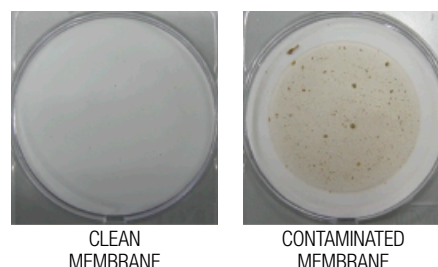

CONTAMINATION MANAGEMENT

- CUMULATIVE DISTRIBUTION OF THE PARTICLES SIZE - ISO 4406

The level of contamination is defined by counting the number of particles of certain dimensions per unit of volume of fluid. Measurement is performed by Automatic Particle Counters (APC).

Following the count, the contamination classes are determined, corresponding to the number of particles detected in the unit of fluid.

The most common classification methods follow ISO 4406 and SAE AS 4059 (Aerospace Sector) regulations.

NAS 1638 is still used although obsolete.

Classification example according to ISO 4406

The code refers to the number of particles of the same size or greater than 4, 6 or 14 μm in a 1 ml fluid.

Class	Number of particles per ml	
	Over	Up to
28	1 300 000	2 500 000
27	640 000	1 300 000
26	320 000	640 000
25	160 000	320 000
24	80 000	160 000
23	40 000	80 000
22	20 000	40 000
21	10 000	20 000
20	5 000	10 000
19	2 500	5 000
18	1 300	2 500
17	640	1 300
16	320	640
15	160	320
14	80	160
13	40	80
12	20	40
11	10	20
10	5	10
9	2.5	5
8	1.3	2.5
7	0.64	1.3
6	0.32	0.64
5	0.16	0.32
4	0.08	0.16
3	0.04	0.08
2	0.02	0.04
1	0.01	0.02
0	0	0.01

- > 4 $\mu\text{m}_{(c)}$ = 350 particles
 - > 6 $\mu\text{m}_{(c)}$ = 100 particles
 - > 14 $\mu\text{m}_{(c)}$ = 25 particles
- 16 / 14 / 12

ISO 4406:2017 Cleanliness Code System

Microscope counting examines the particles differently to APCs and the code is given with two scale numbers only.

These are at 5 μm and 15 μm equivalent to the 6 $\mu\text{m}_{(c)}$ and 14 $\mu\text{m}_{(c)}$ of APCs.

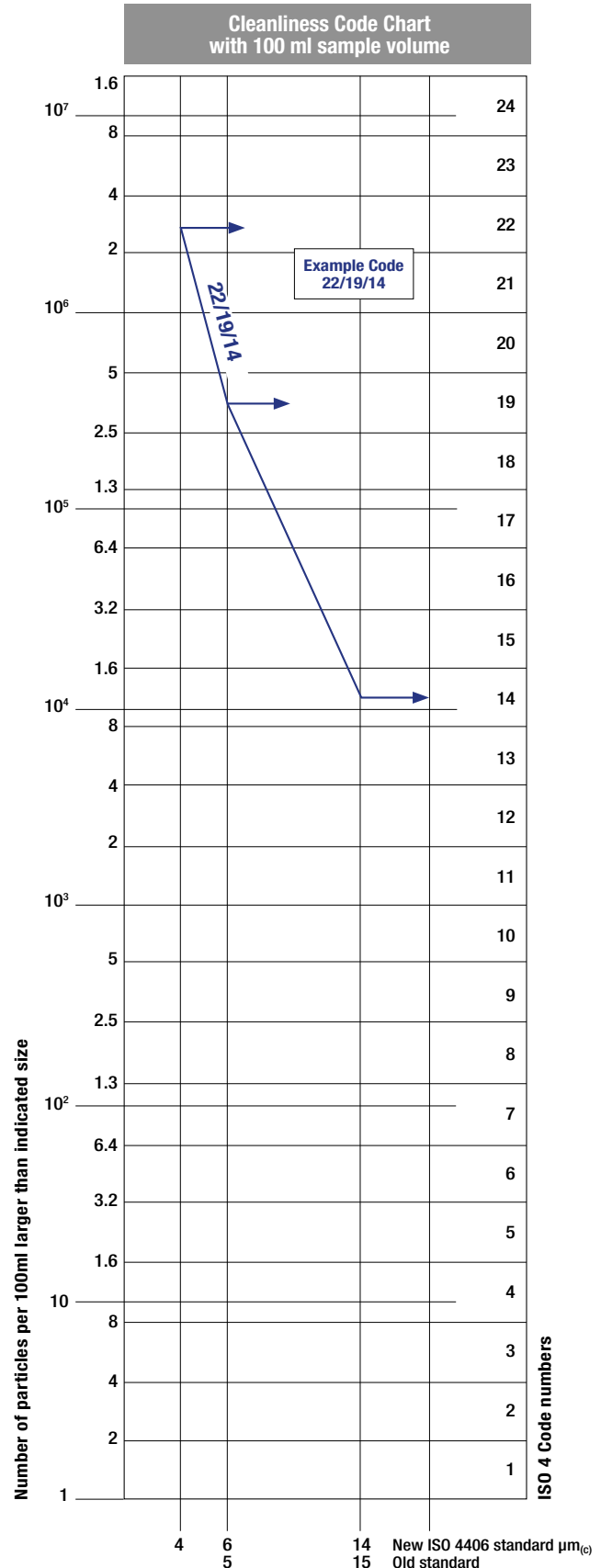

- CUMULATIVE DISTRIBUTION OF THE PARTICLES SIZE - SAE AS 4059-1 and SAE AS 4059-2

Classification example according to SAE AS 4059-1 and SAE AS 4059-2

The code, prepared for the aerospace industry, is based on the size, quantity, and particle spacing in a 100 ml fluid sample. The contamination classes are defined by numeric codes, the size of the contaminant is identified by letters (A-F).

It can be made a differential measurement (Table 1) or a cumulative measurement (Table 2)

Table 1 - Class for differential measurement

Class	Dimension of contaminant				
	6÷14 µm _(c)	14÷21 µm _(c)	21÷38 µm _(c)	38÷70 µm _(c)	>70 µm _(c)
00	125	22	4	1	0
0	250	44	8	2	0
1	500	89	16	3	1
2	1 000	178	32	6	1
3	2 000	356	63	11	2
4	4 000	712	126	22	4
5	8 000	1 425	253	45	8
6	16 000	2 850	506	90	16
7	32 000	5 700	1 012	180	32
8	64 000	11 400	2 025	360	64
9	128 000	22 800	4 050	720	128
10	256 000	45 600	8 100	1 440	256
11	512 000	91 200	16 200	2 880	512
12	1 024 000	182 400	32 400	5 760	1 024

6÷14 µm _(c) = 15 000 particles
14÷21 µm _(c) = 2 200 particles
21÷38 µm _(c) = 200 particles
38÷70 µm _(c) = 35 particles
> 70 µm _(c) = 3 particles
Class 6

Table 2 - Class for cumulative measurement

Class	Dimension of contaminant					
	>4 µm _(c) A	>6 µm _(c) B	>14 µm _(c) C	>21 µm _(c) D	>38 µm _(c) E	>70 µm _(c) F
000	195	76	14	3	1	0
00	390	152	27	5	1	0
0	780	304	54	10	2	0
1	1 560	609	109	20	4	1
2	3 120	1 217	217	39	7	1
3	6 250	2 432	432	76	13	2
4	12 500	4 864	864	152	26	4
5	25 000	9 731	1 731	306	53	8
6	50 000	19 462	3 462	612	106	16
7	100 000	38 924	6 924	1 224	212	32
8	200 000	77 849	13 849	2 449	424	64
9	400 000	155 698	27 698	4 898	848	128
10	800 000	311 396	55 396	9 796	1 696	256
11	1 600 000	622 792	110 792	19 592	3 392	512
12	3 200 000	1 245 584	221 584	39 184	6 784	1 024

> 4 µm _(c) = 45 000 particles
> 6 µm _(c) = 15 000 particles
> 14 µm _(c) = 1 500 particles
> 21 µm _(c) = 250 particles
> 38 µm _(c) = 15 particles
> 70 µm _(c) = 3 particles
Class from 2F to 4E

- CLASSES OF CONTAMINATION ACCORDING TO NAS 1638 (January 1964)

The NAS system was originally developed in 1964 to define contamination classes for the contamination contained within aircraft components.

The application of this standard was extended to industrial hydraulic systems simply because nothing else existed at the time.

The coding system defines the maximum numbers permitted of 100ml volume at various size intervals (differential counts) rather than using cumulative counts as in ISO 4406:1999. Although there is no guidance given in the standard on how to quote the levels, most industrial users quote a single code which is the highest recorded in all sizes and this convention is used on MP Filtri APC's.

The contamination classes are defined by a number (from 00 to 12) which indicates the maximum number of particles per 100 ml, counted on a differential basis, in a given size bracket.

Size Range Classes (in microns)

Maximum Contamination Limits per 100 ml					
Class	5÷15	15÷25	25÷50	50÷100	>100
00	125	22	4	1	0
0	250	44	8	2	0
1	500	89	16	3	1
2	1 000	178	32	6	1
3	2 000	356	63	11	2
4	4 000	712	126	22	4
5	8 000	1 425	253	45	8
6	16 000	2 850	506	90	16
7	32 000	5 700	1 012	180	32
8	64 000	11 400	2 025	360	64
9	128 000	22 800	4 050	720	128
10	256 000	45 600	8 100	1 440	256
11	512 000	91 200	16 200	2 880	512
12	1 024 000	182 400	32 400	5 760	1 024

5÷15 µm = 42 000 particles
15÷25 µm = 2 200 particles
25÷50 µm = 150 particles
50÷100 µm = 18 particles
> 100 µm = 3 particles
Class NAS 8

- CUMULATIVE DISTRIBUTION OF THE PARTICLES SIZE - ISO 4407

The level of contamination is defined by counting the number of particles collected by a laboratory membrane per unit of fluid volume. The measurement is done by a microscope.

The membrane must be cleaned, dried and desiccated, with fluid and conditions defined by the Standard. The fluid volume is filtered through the membrane, using a suitable suction system.

The level of contamination is identified by dividing the membrane into a predefined number of areas and by counting the contaminant particles using a suitable laboratory microscope.

MICROSCOPE CONTROL AND MEASUREMENT



COMPARISON PHOTOGRAPHS

1 graduation = 10µm



ISO 4406:1999	Class 16/14/11	Class 22/20/17
SAE AS4059E Table 1	Class 5	Class 11
NAS 1638	Class 5	Class 11
SAE AS4059E Table 2	Class 6A/5B/5C	Class 12A/11B/11C

- CLEANLINESS CODE COMPARISON

Although ISO 4406:2017 standard is being used extensively within the hydraulics industry other standards are occasionally required and a comparison may be requested. The table below gives a very general comparison but often no direct comparison is possible due to the different classes and sizes involved.

ISO 4406:2017	SAE AS4059 Table 2	SAE AS4059 Table 1	NAS 1638
> 4 $\mu\text{m}_{(c)}$ 6 $\mu\text{m}_{(c)}$ 14 $\mu\text{m}_{(c)}$	> 4 $\mu\text{m}_{(c)}$ 6 $\mu\text{m}_{(c)}$ 14 $\mu\text{m}_{(c)}$	4-6 6-14 14-21 21-38 38-70 >70	5-15 15-25 25-50 50-100 >100
23 / 21 / 18	13A / 12B / 12C	12	12
22 / 20 / 17	12A / 11B / 11C	11	11
21 / 19 / 16	11A / 10B / 10C	10	10
20 / 18 / 15	10A / 9B / 9B	9	9
19 / 17 / 14	9A / 8B / 8C	8	8
18 / 16 / 13	8A / 7B / 7C	7	7
17 / 15 / 12	7A / 6B / 6C	6	6
16 / 14 / 11	6A / 5B / 5C	5	5
15 / 13 / 10	5A / 4B / 4C	4	4
14 / 12 / 09	4A / 3B / 3C	3	3

5 RECOMMENDED CONTAMINATION CLASSES

Any are the nature and the properties of fluids, they are inevitably subject to contamination. The level of contamination can be managed by using special components called filters.

Hydraulic components builders, knowing the problem of contamination, recommend the filtration level appropriate to the use of their products.

Example of recommended contamination levels for pressures below 140 bar.

Piston pumps with fixed flow rate	•					
Piston pumps with variable flow rate			•			
Vane pumps with fixed flow rate		•				
Vane pumps with variable flow			•			
Engines	•					
Hydraulic cylinders	•					
Actuators					•	
Test benches						•
Check valve	•					
Directional valves	•					
Flow regulating valves	•					
Proportional valves				•		
Servo-valves					•	
Flat bearings			•			
Ball bearings				•		
ISO 4406 CODE	20/18/15	19/17/14	18/16/13	17/15/12	16/14/11	15/13/10
Recommended filtration $\beta_{x(c)} \geq 1.000$	$\beta_{20(c)} > 1000$	$\beta_{15(c)} > 1000$	$\beta_{10(c)} > 1000$	$\beta_{7(c)} > 1000$	$\beta_{7(c)} > 1000$	$\beta_{5(c)} > 1000$

6 WATER IN HYDRAULIC AND LUBRICATING FLUIDS

Water Content

In mineral oils and non aqueous resistant fluids water is undesirable. Mineral oil usually has a water content of 50-300 ppm (@40°C) which it can support without adverse consequences.

Once the water content exceeds about 300ppm the oil starts to appear hazy. Above this level there is a danger of free water accumulating in the system in areas of low flow. This can lead to corrosion and accelerated wear.

Similarly, fire resistant fluids have a natural water which may be different to mineral oil.

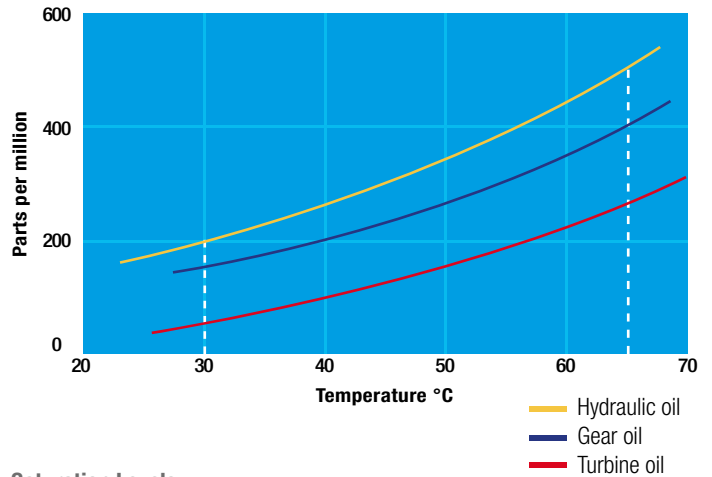

Saturation Levels

Since the effects of free (also emulsified) water is more harmful than those of dissolved water, water levels should remain well below the saturation point.

However, even water in solution can cause damage and therefore every reasonable effort should be made to keep saturation levels as low as possible. There is no such thing as too little water. As a guideline, we recommend maintaining saturation levels below 50% in all equipment.

TYPICAL WATER SATURATION LEVEL FOR NEW OILS

Examples:

Hydraulic oil @ 30°C = 200ppm = 100% saturation

Hydraulic oil @ 65°C = 500ppm = 100% saturation

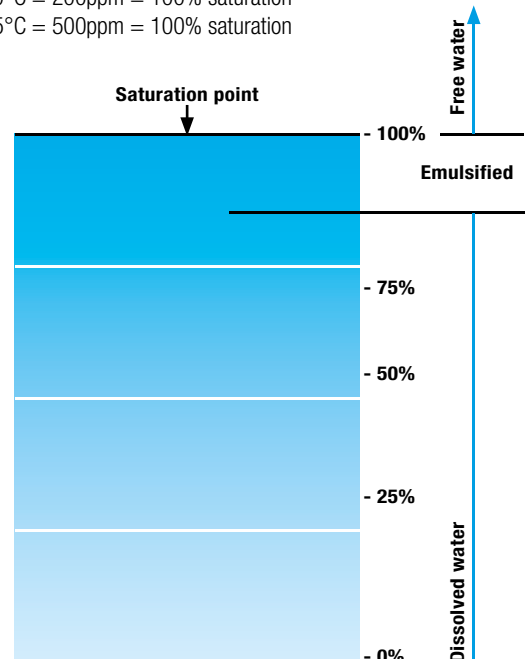

W - Water and Temperature Sensing

"W" option, in MP Filtri Contamination Monitoring Products, indicates water content as a percentage of saturation and oil temperature in degrees centigrade. 100% RH corresponds to the point at which free water can exist in the fluid. i.e. the fluid is no longer able to hold the water in a dissolved solution.

The sensor can help provide early indication of costly failure due to free water, including but not exclusive to:

- Corrosion
- Metal surface fatigue e.g. bearing failure
- Reduced lubrication & load carrying characteristics

Different oils have different saturation levels and therefore RH (relative humidity) % is the best and most practical measurement.

Water absorber

Water is present everywhere, during storage, handling and servicing.

MP Filtri filter elements feature an absorbent media which protects hydraulic systems from both particulate and water contamination.

MP Filtri's filter element technology is available with inorganic microfiber media with a filtration rating 25 μm (therefore identified with media designation WA025, providing absolute filtration of solid particles to $\beta_{X(C)} = 1000$).

Absorbent media is made by water absorbent fibres which increase in size during the absorption process.

Free water is thus bonded to the filter media and completely removed from the system (it cannot even be squeezed out).

By removing water from your fluid power system, you can prevent such key problems as:

- corrosion (metal etching)
- loss of lubricant power
- accelerated abrasive wear in hydraulic components
- valve-locking
- bearing fatigue
- viscosity variance (reduction in lubricating properties)
- additive precipitation and oil oxidation
- increase in acidity level
- increased electrical conductivity (loss of dielectric strength)
- slow/weak response of control systems

Product availability - UFM Series:

- UFM 041
- UFM 051
- UFM 091
- UFM 181
- UFM 919

Filter Media



Fabric that absorbs water

Absorber media layer



The Filter Media has absorbed water

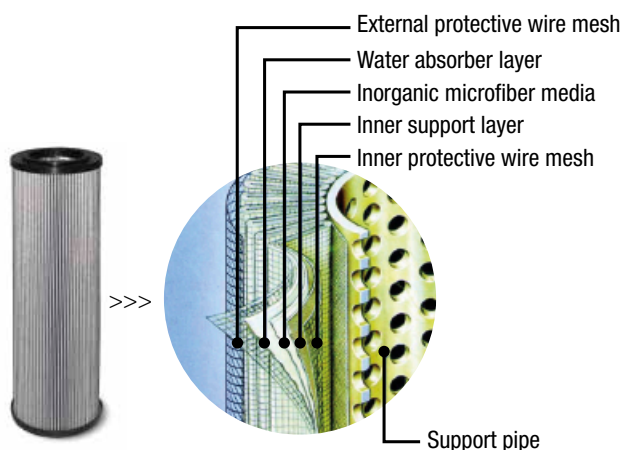

Filtered to perfection

Our mobile filtration units provide the perfect solution for the oil maintenance of your lubrication and hydraulic fluids in off-line filtration applications.

Benefits:

- **Versatile and compact design**
- **Filtering and continuous cleaning of systems**
- **Removal of water from hydraulic systems (when fitted with a spin on filter)**
- **Particle counting to determine the Contamination Class according to ISO4406, NAS1638, AS4059**

Applications:

- **For oil changes, initial filling and flushing cycles in hydraulic and lubrication systems**
- **Pulp and paper mill equipment**
- **Construction machinery**
- **Large central hydraulic power units**
- **Injection moulding equipment**
- **Stamping presses**

Mobile filtration units

UFM 015



UFM 041



UFM 051



UFM 091-181-919



FTU



UFM 015	page 95
UFM 041	101
UFM 051	107
UFM 091	113
UFM 181	119
UFM 919	125
FTU 080	131

UFM 015

Mobile filtration unit 15 l/min flow rate



Description

Mobile filtration units

The UFM 015 is a portable oil transfer/filtration unit, specifically designed for both filling/transferring hydraulic oils from containers to the hydraulic tank as well as filtering and cleaning hydraulic systems.

The unit utilises Spin-On standard cartridge (supplied as option), available in two lengths, thus increasing the dirt holding capacity and lowering pressure drop of the unit.

The unit has the flexibility in being able to offer a wide range of medias and micro ratings to suit any application.

The unit is very compact and lightweight.

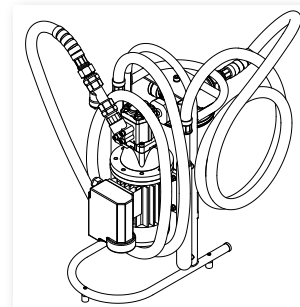

> Features & Benefits

- Handle size
- Light
- Easy to use
- Easy maintenance
- Reliable
- Absolute filtration



Technical data

Pump

Gear pump

Electric Motor

0.18 Kw 230 Volt single phase electric motor

Flow (l/min)

15 l/min - 1450 r.p.m.

Max. Operation Pressure

4 bar

Viscosity range

Min. operation 10 cSt

Max. operation 200 cSt

Max. only for cold start 400 cSt

Suction Filter

Type Y filtration 500 µm

Filtration Rating

1/3/6/10/25 µm $\beta > 1000$ flow through the element Out/In

Bypass valve

Rating 2.5 bar

Fluid Temperature

From +5° to 60 °C

Ambient Temperature

From +5° to 40 °C

Protection Class

IP 55

Seal

NBR

Fluid Compatibility

Mineral Oil - Other on request

Suction hose

DN18 length 2500 mm

lance

DN/OD20 length 400 mm

Pressure hose

DN18 length 2500 mm

lance

DN/OD18 length 400 mm

Weight

14.8 kg

Equipment

Visual clogging indicator (gauge)

 Standard

Designation & Ordering code

MOBILE FILTRATION UNIT UFM 015

Series	Configuration example:	UFM	015	M	A	1	0	0	0	P01
UFM										
Size										
015 15 l/min										
Electric motor										
M 220V single phase										
Seals										
A NBR										
Pressure gauges and Clogging indicators	Mettere solo «Clogging Indicators» anche in EN?									
1 Manometer										
Cartridge										
0 Without cartridge										
Filtration surface										
0 Not provided										
Option										
0 No options										
Option										
P01 MP Filtri standard										
Pxx Customized										

Cartridge should be ordered separately

CARTRIDGE STANDARD LENGTH

Inorganic microfibre	Wire mesh element
CS 100 A01 A P01	CS 100 M25 A P01
CS 100 A03 A P01	CS 100 M60 A P01
CS 100 A06 A P01	
CS 100 A10 A P01	
CS 100 A25 A P01	

CARTRIDGE EXTENDED LENGTH

Inorganic microfibre	Wire mesh element
CS 150 A01 A P01	CS 150 M25 A P01
CS 150 A03 A P01	CS 150 M60 A P01
CS 150 A06 A P01	
CS 150 A10 A P01	
CS 150 A25 A P01	

WATER REMOVAL - CARTRIDGE EXTENDED LENGTH

Multi-Layer water absorber
CW150P10A

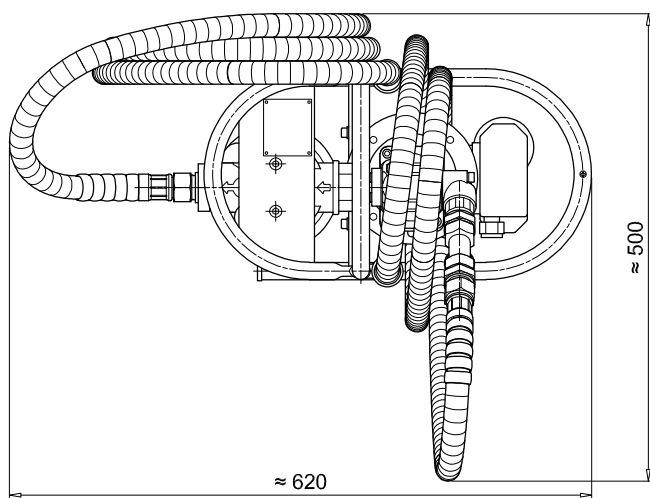
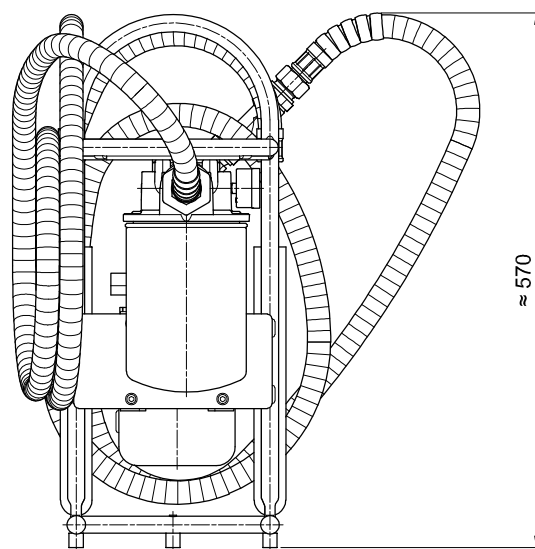
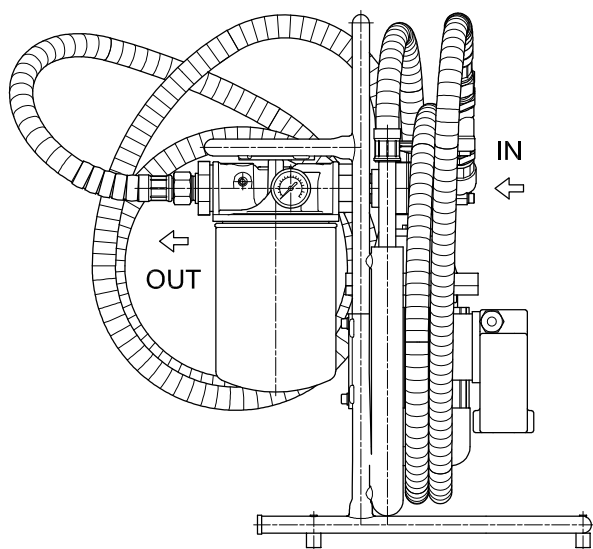

HYDRAULIC CIRCUIT

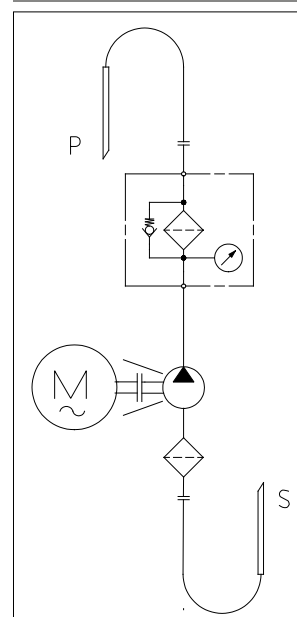

UFM 041

Mobile filtration unit 34 l/min flow rate



Description

Mobile filtration units

UFM 041 mobile filtration units suitable for filling and refilling of filtered hydraulic fluids and lubrication tanks.

The filter unit connected to off-line to the tank (recommended maximum volume of 350/500 L.), can be used as a support to the filtration plant on start-up for fast flushing action, either as additional filtration systems with a high incidence of contamination.

Continued use is recommended for the version with three phase electric motor.

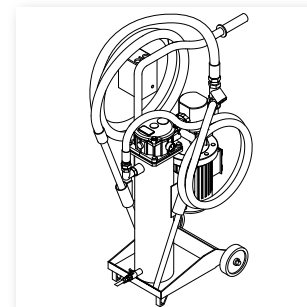

> Features & Benefits

- Compact size
- Light
- Easy to use
- Easy maintenance
- Reliable
- Absolute filtration



Technical data

Pump

Gear pump

Electric Motor

0.75 Kw 230 Volt single phase electric motor
0.75 Kw 400/230 Volt three phase electric motor

Flow (l/min)

34 l/min - 1450 r.p.m.

Max. Operation Pressure

5 bar

Viscosity range

Min. operation 10 cSt
Max. operation 200 cSt
Max. only for cold start 800 cSt

Suction Filter

Type Y filtration 350 µm

Filtration Rating

1/3/6/10/25 µm $\beta > 1000$ flow through the element In/Out

Bypass valve

Rating 2.5 bar

Fluid Temperature

From -10° to +80 °C

Ambient Temperature

From -20° to +45 °C

Protection Class

IP 55

Seal

NBR

Fluid Compatibility

Mineral Oil & Synthetic Oil - Other on request

Suction hose

DN25 length 3000 mm

lance

DN/OD25 length 700 mm

Pressure hose

DN20 length 3000 mm

lance

DN/OD20 length 700 mm

Weight

45 kg

Equipment

Visual clogging indicator (gauge)

 Standard

UFM 041

Designation & Ordering code

MOBILE FILTRATION UNIT UFM 041

Series	Configuration example:	UFM	041	T	A	1	0	1	0	P01
UFM										
Size										
041	34 l/min									
Electric motor										
M	230V single phase									
T	400/230V three phase									
Seals										
A	NBR									
Pressure gauges and Clogging indicators										
1	Manometer									
Filter element										
0	Without element									
Filtration surface										
1	Standard									
Option										
0	No options									
Option										
P01	MP Filtri standard									
Pxx	Customized									

Filtration element should be ordered separately

FILTRATION SURFACE - STANDARD

Inorganic microfibre	Wire mesh element
MR 250 4 A01 A P01	MR 250 4 M25 A P01
MR 250 4 A03 A P01	MR 250 4 M60 A P01
MR 250 4 A06 A P01	
MR 250 4 A10 A P01	
MR 250 4 A16 A P01	
MR 250 4 A25 A P01	

WATER REMOVAL - FILTRATION SURFACE - STANDARD

Multi-Layer water absorber
MR2504WA025AP01

Dimensions

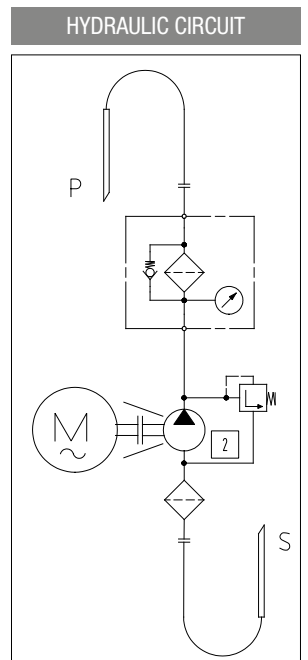
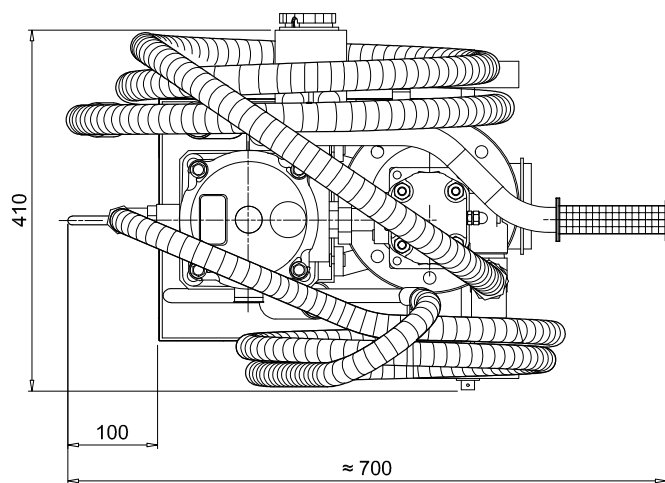
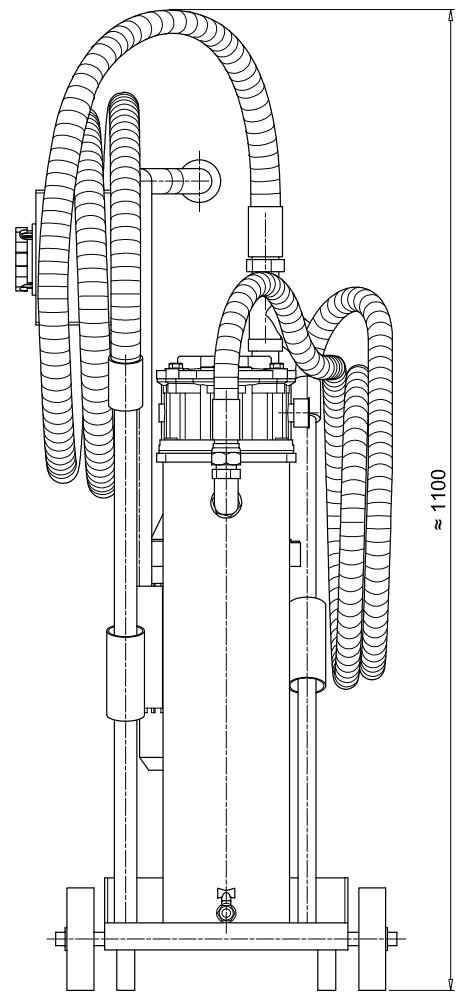
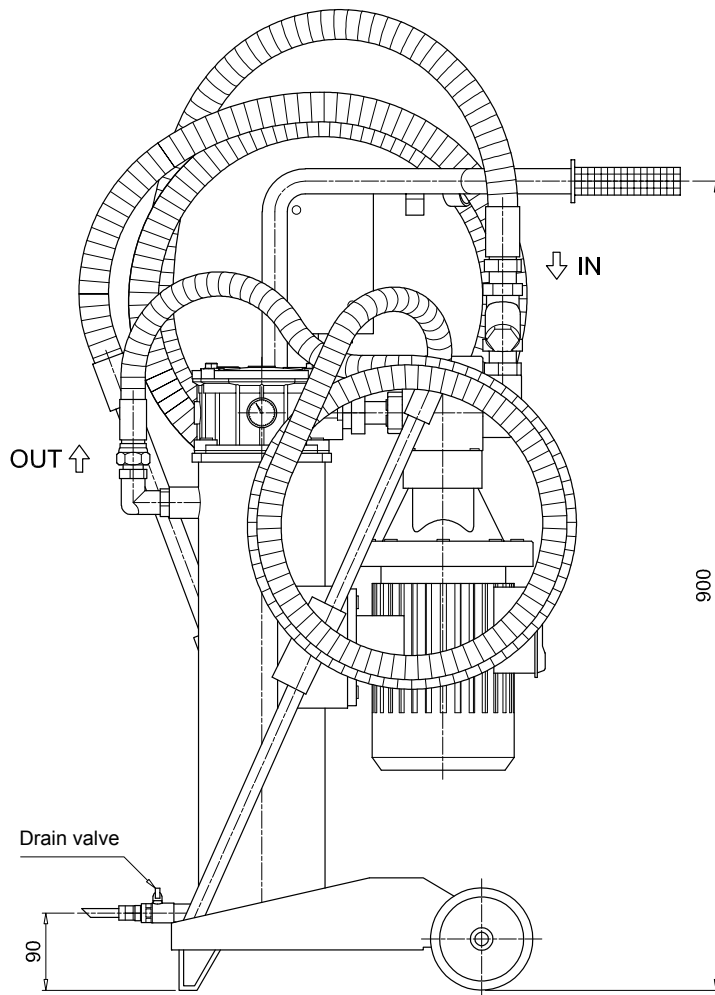

UFM 051

Mobile filtration unit 50 l/min flow rate



Description

Mobile filtration units

UFM 051 mobile filtration units suitable for filling and refilling of filtered hydraulic fluids and lubrication tanks.

The filter unit connected to off-line to the tank (recommended maximum volume of 500/750 L.), can be used as a support to the filtration plant on start-up for fast flushing action, either as additional filtration systems with a high incidence of contamination.

Continued use is recommended for the version with three phase electric motor.

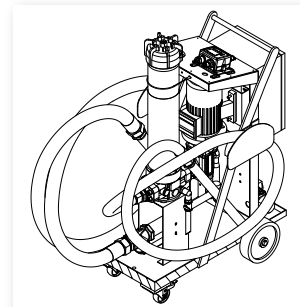

> Features & Benefits

- Compact size
- Continue Operation Pressure 10 bar
- Easy to use
- Easy maintenance
- Reliable
- Absolute filtration
- In-line Contamination Monitor

Available in three configurations:

- configuration with start / stop differential pressure indicator - visual
- configuration with start / stop automatic motor
- cut-out from differential pressure indicator - electrical / visual
- configuration with start / stop phase inverter automatic motor
- cut-out from differential pressure indicator - electrical / visual
- in-line Particle Counter ICM



Technical data

Pump

Gear pump

Electric Motor

1.5 Kw 230 Volt single phase electric motor

1.5 Kw 400/230 Volt three phase electric motor with ICM 2.0

Flow (l/min)

50 l/min - 1450 r.p.m.

Max. Operation Pressure

10 bar

Viscosity range

Min. operation 10 cSt

Max. operation 300 cSt

Max. only for cold start 800 cSt

Suction Filter

Type Y filtration 800 µm

Filtration Rating

1/3/6/10/25 µm $\beta > 1000$ flow through the element Out/In

Bypass valve

Rating 3.5 bar

The bypass can be blocked through the spigot

Fluid Temperature

From -10° to +80 °C

Ambient Temperature

From -20° to +45 °C

Protection Class

IP 55

Fluid Compatibility

Mineral Oil & Synthetic Oil - Other on request

Suction hose

DN32 length 3000 mm

lance

DN/OD42 length 700 mm

Pressure hose

DN25 length 3000 mm

lance

DN/OD30 length 700 mm

Weight

70 kg

Equipment

- Differential Clogging indicator - Visual (setting 3 bar $\pm 10\%$)
- Differential Clogging indicator - Electrical / Visual (setting 3 bar $\pm 10\%$)
- Differential Clogging indicator - Electrical / Visual - with ICM 2.0 (setting 3 bar $\pm 10\%$)

 Standard

Designation & Ordering code

MOBILE FILTRATION UNIT UFM 051

Series	Configuration example:	UFM	051	T	A	2	0	1	0	P01
UFM										
Size										
051	50 l/min									
Electric motor										
M	230V Single phase									
T	400/230V Three phase									
Seals										
A	NBR									
Pressure gauges and Clogging indicators										
2	Manometer + Visual Differential Clogging indicator									
3	Manometer + Electrical/Visual Differential Clogging indicator									
Filter element										
0	Without element									
Filtration surface										
1	Standard									
2	Higher									
Option										
0	No options									
1	ICM 2.0 particle counter (available three phase electric motor only)									
Option										
P01	MP Filtri standard									
Pxx	Customized									

Filtration element should be ordered separately

FILTRATION SURFACE 1 - STANDARD

Inorganic microfibre	Wire mesh element
CU 400 5 A01 A N P01	CU 400 5 M25 A N P01
CU 400 5 A03 A N P01	CU 400 5 M60 A N P01
CU 400 5 A06 A N P01	
CU 400 5 A10 A N P01	
CU 400 5 A16 A N P01	
CU 400 5 A25 A N P01	

FILTRATION SURFACE 2 - HIGHER

Inorganic microfibre	Wire mesh element
CU 400 6 A01 A N P01	CU 400 6 M25 A N P01
CU 400 6 A03 A N P01	CU 400 6 M60 A N P01
CU 400 6 A06 A N P01	
CU 400 6 A10 A N P01	
CU 400 6 A16 A N P01	
CU 400 6 A25 A N P01	

WATER REMOVAL - FILTRATION SURFACE 1 - STANDARD

Multi-Layer water absorber
CU4005WA025ANP01

WATER REMOVAL - FILTRATION SURFACE 2 - HIGHER

Multi-Layer water absorber
CU4006WA025ANP01

Dimensions

Filter length	H1 [mm]
1	1230 standard
2	1530 higher

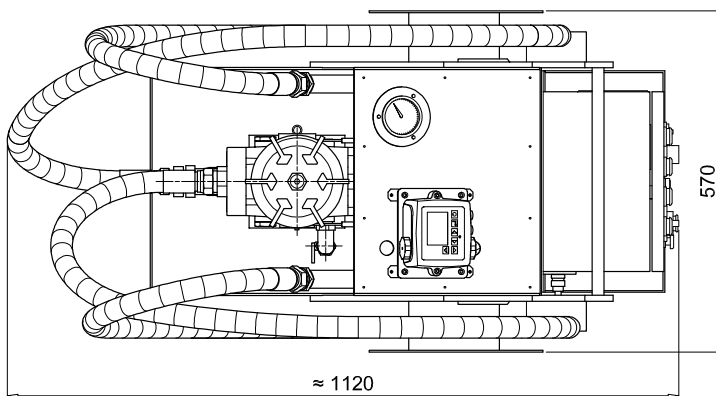
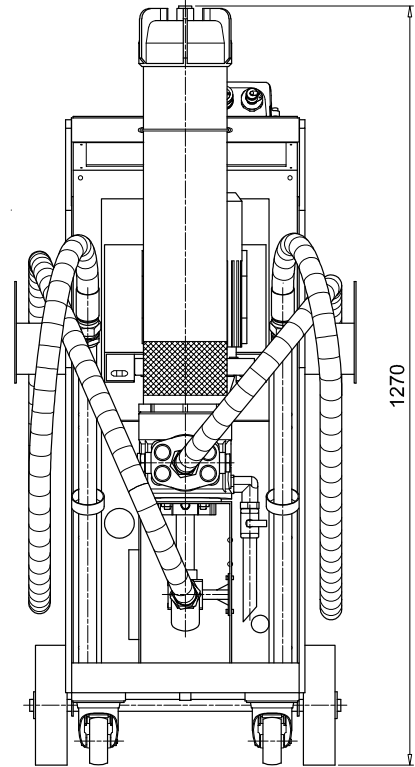
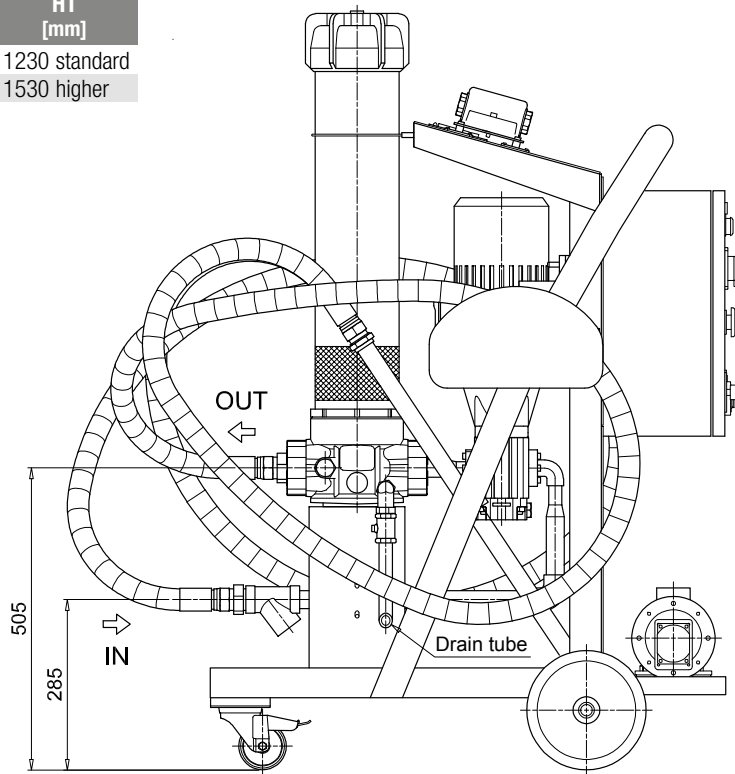

HYDRAULIC CIRCUIT

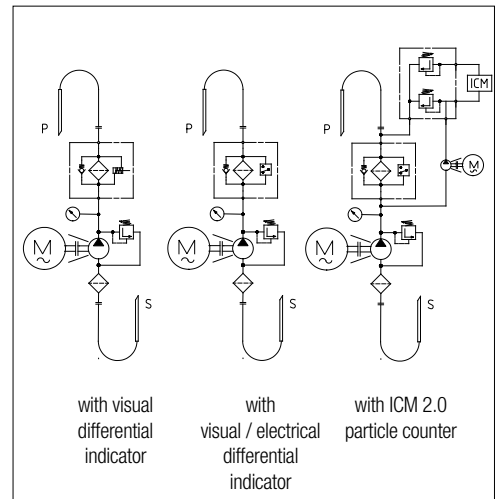

UFM 091

Mobile filtration unit 90 l/min flow rate



Description

Mobile filtration units

UFM 091 mobile filtration units suitable for filling and refilling of filtered hydraulic fluids and lubrication tanks.

The filter unit connected to off-line to the tank, can be used as a support to the filtration plant on start-up for fast flushing action, either as additional filtration systems with a high incidence of contamination.

Recommended maximum tank volume of 900/1300 L.

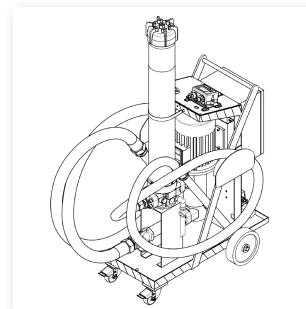

> Features & Benefits

- Compact size
- High flow
- Continue Operation Pressure 10 bar
- Easy to use
- Easy maintenance
- Reliable
- Absolute filtration
- In-line Contamination Monitor

Available in three configurations:

- configuration with start / stop differential pressure indicator - visual
- configuration with start / stop automatic motor
- cut-out from differential pressure indicator - electrical / visual
- configuration with start / stop phase inverter automatic motor
- cut-out from differential pressure indicator - electrical / visual
- in-line Particle Counter ICM



Technical data

<p>Pump Screw pump</p>	<p>Protection Class IP 55</p>
<p>Electric Motor 2.2 kW 400/230 V three phase 4-pole</p>	<p>Seal NBR</p>
<p>Flow (l/min) 90 l/min - 1450 r.p.m.</p>	<p>Fluid Compatibility Mineral Oil & Synthetic Oil - Water Glycol</p>
<p>Max. Operation Pressure 10 bar</p>	<p>Suction hose lance DN50 length 3000 mm DN/OD50 length 700 mm</p>
<p>Viscosity range Min. operation 10 cSt Max. operation 800 cSt Max. only for cold start 2000 cSt</p>	<p>Pressure hose lance DN38 length 3000 mm DN/OD42 length 700 mm</p>
<p>Suction Filter Type Y filtration 800 µm</p>	<p>Weight 105 kg</p>
<p>Filtration Rating 1/3/6/10/25 µm $\beta > 1000$ flow through the element Out/In</p>	<p>Equipment - Differential Clogging indicator - Visual (setting 3 bar $\pm 10\%$) - Differential Clogging indicator - Electrical / Visual (setting 3 bar $\pm 10\%$) - Differential Clogging indicator - Electrical / Visual - with ICM 2.0 (setting 3 bar $\pm 10\%$)</p>
<p>Bypass valve Rating 3.5 bar with bypass. The bypass can be blocked through the spigot</p>	<p>CE Standard</p>
<p>Fluid Temperature From -10° to +80 °C</p>	
<p>Ambient Temperature From -20° to +45 °C</p>	

Designation & Ordering code

MOBILE FILTRATION UNIT UFM 091

Series	Configuration example:	UFM	091	T	A	2	0	2	0	P01
UFM										
Size										
091	90 l/min									
Electric motor										
T	400/230V Three phase									
Seals										
A	NBR									
Pressure gauges and Clogging indicators										
2	Manometer + Visual Differential Clogging indicator									
3	Manometer + Electrical/Visual Differential Clogging indicator									
Filter element										
0	Without element									
Filtration surface										
2	Higher									
Option										
0	No options									
1	ICM 2.0 particle counter									
Option										
P01	MP Filtri standard									
Pxx	Customized									

Filtration element should be ordered separately

FILTRATION SURFACE - HIGHER

Inorganic microfibre	Wire mesh element
CU 400 6 A01 A N P01	CU 400 6 M25 A N P01
CU 400 6 A03 A N P01	CU 400 6 M60 A N P01
CU 400 6 A06 A N P01	
CU 400 6 A10 A N P01	
CU 400 6 A16 A N P01	
CU 400 6 A25 A N P01	

WATER REMOVAL - FILTRATION SURFACE 1 - HIGHER

Multi-Layer water absorber
CU4006WA025ANP01

Dimensions

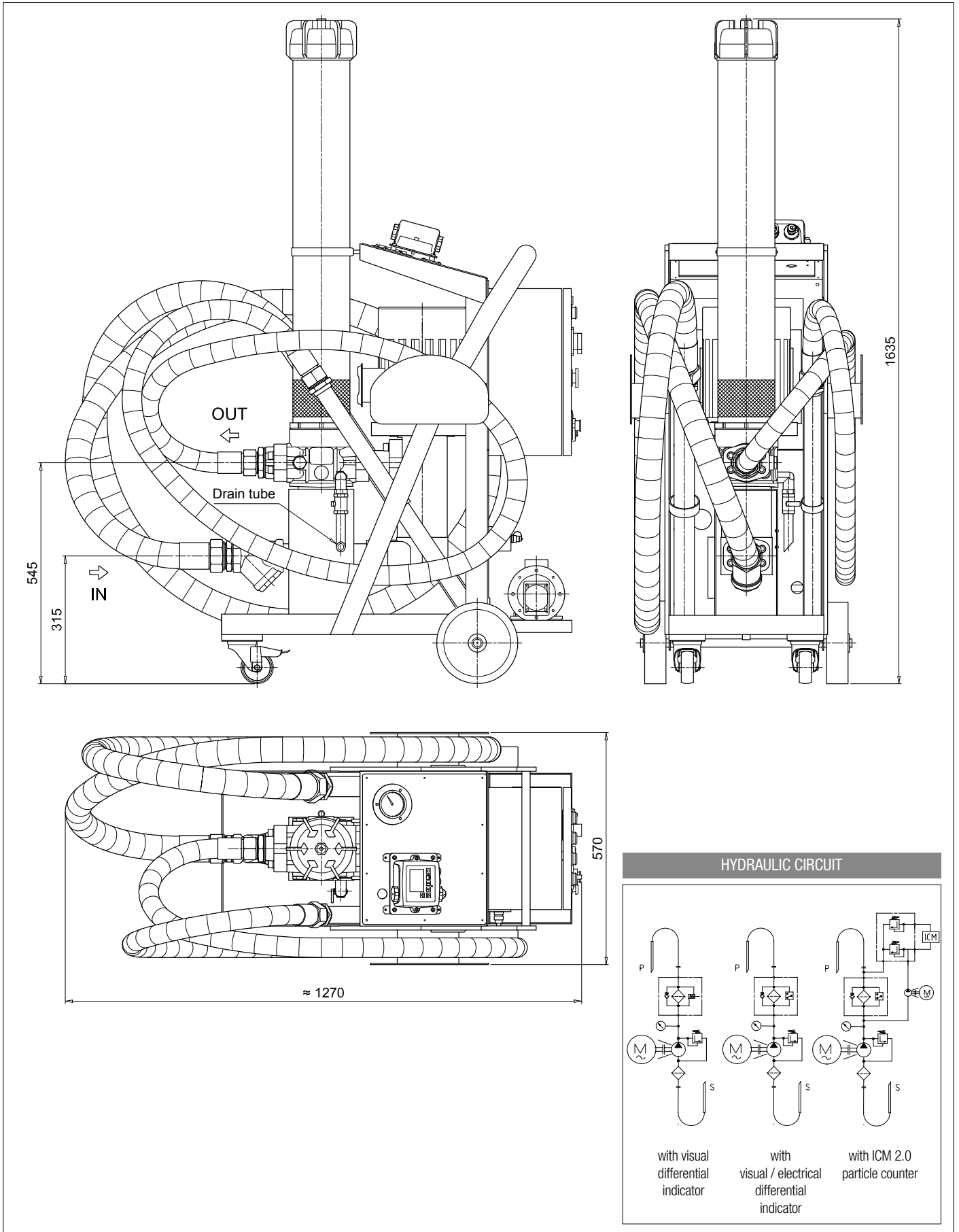

UFM 181

Mobile filtration unit 180 l/min flow rate



Description

Mobile filtration units

UFM 181 mobile filtration units suitable for filling and refilling of filtered hydraulic fluids and lubrication tanks.

The filter unit connected to off-line to the tank, can be used as a support to the filtration plant on start-up for fast flushing action, either as additional filtration systems with a high incidence of contamination.

Recommended maximum tank volume of 1800/2700 L.

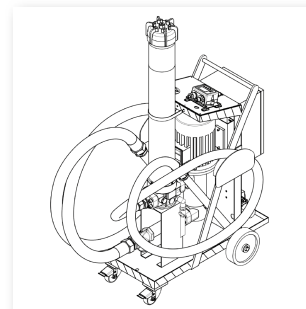

> Features & Benefits

- Compact size
- High flow
- Continue Operation Pressure 10 bar
- Easy to use
- Easy maintenance
- Reliable
- Absolute filtration
- In-line Contamination Monitor

Available in two configurations:

- configuration with start / stop automatic motor
- cut-out from differential pressure indicator - electrical / visual
- configuration with start / stop phase inverter automatic motor
- cut-out from differential pressure indicator - electrical / visual
- in-line Particle Counter ICM



Technical data

Pump

Screw pump

Electric Motor

4 kW 400/230 V three phase 2-pole

Flow (l/min)

180 l/min - 2900 r.p.m.

Max. Operation Pressure

10 bar

Viscosity range

Min. operation 10 cSt

Max. operation 800 cSt

Max. only for cold start 2000 cSt

Suction Filter

Type Y filtration 800 µm

Filtration Rating

1/3/6/10/25 µm $\beta > 1000$ flow through the element Out/In

Bypass valve

Rating 3.5 bar with bypass.

The bypass can be blocked through the spigot

Fluid Temperature

From -10° to +80 °C

Ambient Temperature

From -20° to +45 °C

Protection Class

IP 55

Seal

NBR

Fluid Compatibility

Mineral Oil & Synthetic Oil - Water Glycol

Suction hose

DN50 length 3000 mm

lance

DN/OD50 length 700 mm

Pressure hose

DN38 length 3000 mm

lance

DN/OD42 length 700 mm

Weight

109 kg

Equipment

- Differential Clogging indicator - Electrical / Visual (setting 3 bar $\pm 10\%$)

- Differential Clogging indicator - Electrical / Visual - with ICM 2.0 (setting 3 bar $\pm 10\%$)



UFM 181

Designation & Ordering code

MOBILE FILTRATION UNIT UFM 181

Series	Configuration example:	UFM	181	T	A	3	0	2	0	P01
UFM										
Size										
181	180 l/min									
Electric motor										
T	400/230V Three phase									
Seals										
A	NBR									
Pressure gauges and Clogging indicators										
3	Manometer + Electrical/Visual Differential Clogging indicator									
Filter element										
0	Without element									
Filtration surface										
2	Higher									
Option										
0	No options									
1	ICM 2.0 particle counter									
Option										
P01	MP Filtri standard									
Pxx	Customized									

Filtration element should be ordered separately

FILTRATION SURFACE - HIGHER

Inorganic microfibre	Wire mesh element
CU 400 6 A01 A N P01	CU 400 6 M25 A N P01
CU 400 6 A03 A N P01	CU 400 6 M60 A N P01
CU 400 6 A06 A N P01	
CU 400 6 A10 A N P01	
CU 400 6 A16 A N P01	
CU 400 6 A25 A N P01	

WATER REMOVAL - FILTRATION SURFACE 1 - HIGHER

Multi-Layer water absorber
CU4006WA025ANP01

Dimensions

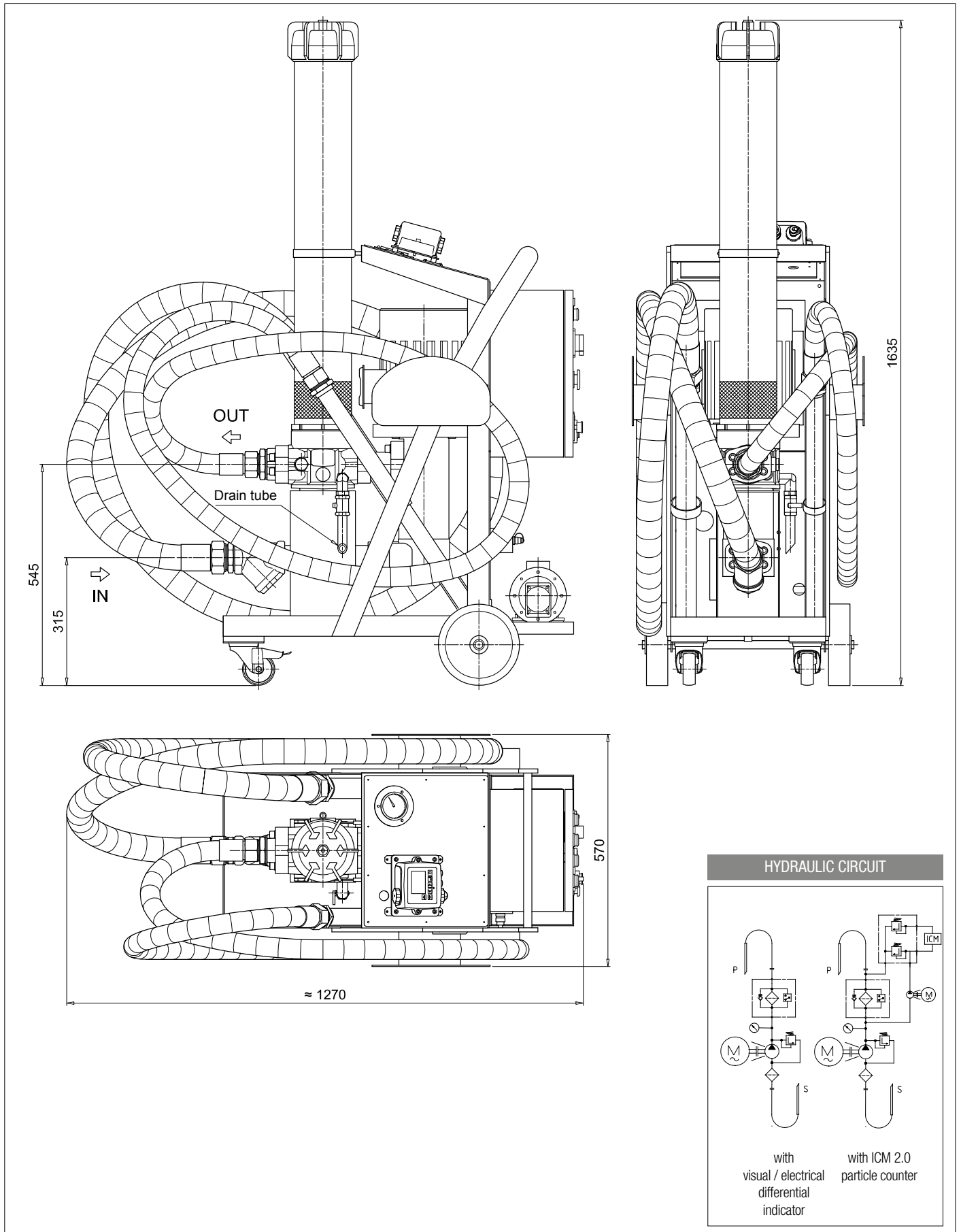

UFM 919

Mobile filtration unit 90/180 l/min flow rate



Description

Mobile filtration units

UFM 919 mobile filtration units suitable for filling and refilling of filtered hydraulic fluids and lubrication tanks.

The filter unit connected to off-line to the tank, can be used as a support to the filtration plant on start-up for fast flushing action, either as additional filtration systems with a high incidence of contamination.

Two-speed electric motor with programmable flow of 90 or 180 l/min.

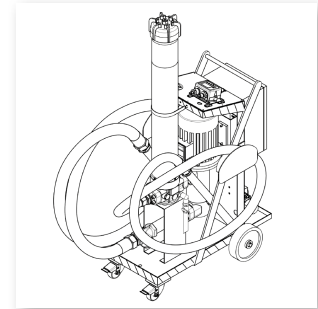

> Features & Benefits

- Compact size
- High flow
- Continue Operation Pressure 10 bar
- Easy to use
- Easy maintenance
- Reliable
- Absolute filtration
- In-line Contamination Monitor

Possible applications

- Flow rate 90 l/min for filling or topping up tanks with a volume of less than 1000 liters
- Flow rate 90 l/min for depollution of tanks with a volume of less than 1000 liters
- Flow rate 90 l / min for the treatment of high viscosity oils
- Flow rate 90 l / min for a cold start phase then flow rate 180 l/min after temperature rise.

- Flow rate 180 l/min for filling or topping up tanks with a volume greater than 2000 liters
- Flow rate 180 l/min for the depollution of tanks with a volume of less than 2000 liters

Available in two configurations:

- configuration with start / stop automatic motor
- cut-out from differential pressure indicator - electrical / visual
- configuration with start / stop phase inverter automatic motor
- cut-out from differential pressure indicator - electrical / visual
- in-line Particle Counter ICM 2.0



Technical data

<p>Pump Screw pump</p>	<p>Protection Class IP 55</p>
<p>Electric Motor 3.7/5 kW 400/230 V three phase 2/4-pole</p>	<p>Seal NBR</p>
<p>Flow (l/min) 90 l/min - 1450 r.p.m. / 180 l/min - 2900 r.p.m.</p>	<p>Fluid Compatibility Mineral Oil & Synthetic Oil - Water Glycol</p>
<p>Max. Operation Pressure 10 bar</p>	<p>Suction hose lance lance 90° DN50 length 3000 mm DN/OD50 length 700 mm DN/OD40 length 700 mm</p>
<p>Viscosity range Min. operation 10 cSt Max. operation 800 cSt Max. only for cold start 2000 cSt</p>	<p>Pressure hose lance DN38 length 3000 mm DN/OD42 length 700 mm</p>
<p>Suction Filter Type Y filtration 800 µm</p>	<p>Weight 120 kg</p>
<p>Filtration Rating 1/3/6/10/25 µm β>1000 flow through the element Out/In</p>	<p>Equipment - Differential Clogging indicator - Electrical / Visual (setting 3 bar ±10%) - Differential Clogging indicator - Electrical / Visual - with ICM 2.0 (setting 3 bar ±10%)</p>
<p>Bypass valve Rating 3.5 bar with bypass. The bypass can be blocked through the spigot</p>	<p>CE Standard</p>
<p>Fluid Temperature From -10° to +80 °C</p>	
<p>Ambient Temperature From -20° to +45 °C</p>	

UFM 919

Designation & Ordering code

MOBILE FILTRATION UNIT UFM 919

Series	Configuration example:	UFM	919	T	A	3	0	2	0	P01
UFM										
Size										
919	90-180 l/min									
Electric motor										
T	400/230V Three phase - 2/4 pole									
Seals										
A	NBR									
Pressure gauges and Clogging indicators										
3	Manometer + Electrical/Visual Differential Clogging indicator									
Filter element										
0	Without element									
Filtration surface										
2	Higher									
Option										
0	No options									
1	ICM 2.0 particle counter									
Option										
P01	MP Filtri standard									
Pxx	Customized									

Filtration element should be ordered separately

FILTRATION SURFACE - HIGHER

Inorganic microfibre	Wire mesh element
CU 400 6 A01 A N P01	CU 400 6 M25 A N P01
CU 400 6 A03 A N P01	CU 400 6 M60 A N P01
CU 400 6 A06 A N P01	
CU 400 6 A10 A N P01	
CU 400 6 A16 A N P01	
CU 400 6 A25 A N P01	

WATER REMOVAL - FILTRATION SURFACE 1 - HIGHER

Multi-Layer water absorber
CU4006WA025ANP01

Dimensions

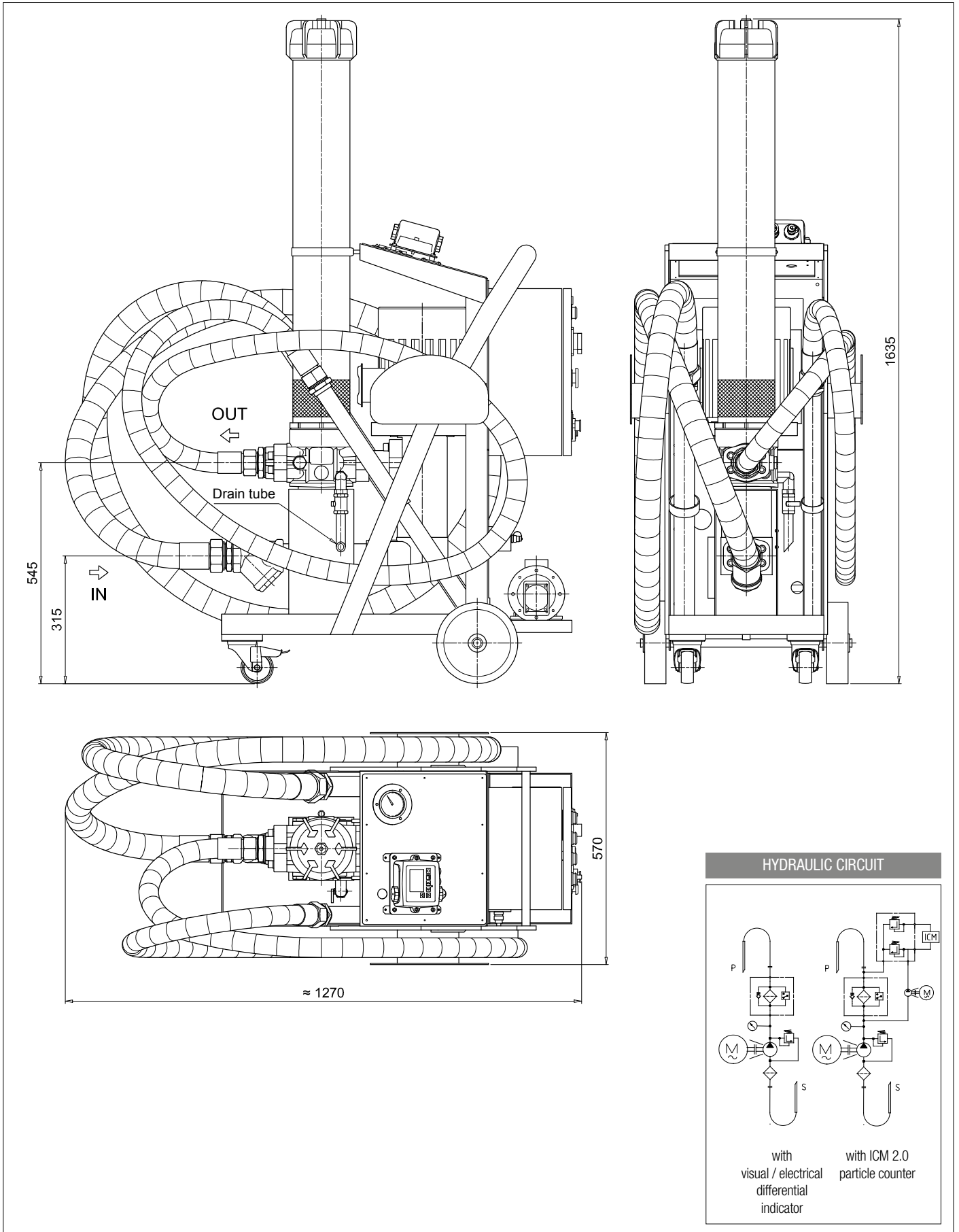

FTU 080

Fluid transfer unit with ICM 2.0 (In-line Contamination Monitor)



Description

Fluid Transfer Unit

FTU 080 Fluid Transfer unit suitable for filling, recirculation - via onboard 80L reservoir - and emptying of filtered hydraulic fluids and lubrication tanks.

The FTU can be utilised either as additional filtration to a system with a high incidence of contamination, or can be used as a standalone recirculating filtration circuit to clean fluid to a predetermined contamination level - monitored by the onboard ICM - prior to transfer of fluid to the system.

> Features & Benefits

- Compact size
- Easy to use
- Easy maintenance
- Reliable
- Absolute filtration
- In-line Contamination Monitor

Possible applications

- Low flow rate for filling of reservoirs
- Low-flow filtration for off-line tanks
- Pre filtration ability of fluid prior to filling of hydraulic system



Technical data

Pump

Gear pump

Electric Motor

0.75kW 1400rpm, 110/230V single phase

Flow (l/min)

15 l/min

Max. Operation Pressure

3.5 bar

Inlet

Inlet (pump protection) filtration steel 250µm strainer

Viscosity

150 cSt maximum fluid viscosity

Suction Filter

250 µm metal mesh strainers

Bypass valve

Rating 3.5 bar with bypass

Filtration

Water removal "spin-on" type, bypass set at 1.75 bar.
In-line filtration 3 µm absolute β 1000 element bypass set at 3 bar.

Filtration rating

See designation order for cartridge and filter elements

Control

Electrical Control Box

Indicator

Delivery line electric cut out switch

Ambient Temperature

From -10 °C to 80 °C

Working temperature

From 0 °C to 40 °C

Protection Class

IP 55

Seal

NBR

Fluid Compatibility

Mineral oil compatible - please contact sales team for queries about other fluids

Hoses

Flexible hoses - SAE100R4 1" BSP swaged females 2mtr long hose

Oil level

Sight glass and filler with integrated electric float cut out switch

Weight

200 kg

Mounting

Heavy duty trolley and wheels

CE Standard

Designation & Ordering code

FLUID TRANSFER UNIT FTU	
Mobile filtration unit FTU Fluid Transfer Unit	Configuration example: FTU 1 1 15 2 1 M250 SL4305
Onboard reservoir 1 80 litres	
In-line contamination monitor 1 With ICM	
Flow rate 15 15 l/min	
Motor power 2 0.75 kW, 1400 rpm	
Voltage 1 110V - 50Hz single phase 2 240V - 50Hz single phase	
Inlet filtration M250 250 µm suction strainer (internal of reservoir)	
Outlet filtration SL4305 Single spin on plus LMP length 5	

Filtration element is not included and should be ordered separately.

Outlet filtration options:

LMP: CU400 5 A03, A06, A10, A16, A25 - **SPIN-ON:** CS150 A03, A06, A10, A25 - CS150 P10, P25 - **WATER REMOVAL:** CW150 P10, P25

CARTRIDGE STANDARD LENGTH

Inorganic microfibre	Wire mesh element
CS 100 A01 A P01	CS 100 M25 A P01
CS 100 A03 A P01	CS 100 M60 A P01
CS 100 A06 A P01	
CS 100 A10 A P01	
CS 100 A25 A P01	

CARTRIDGE EXTENDED LENGTH

Inorganic microfibre	Wire mesh element
CS 150 A01 A P01	CS 150 M25 A P01
CS 150 A03 A P01	CS 150 M60 A P01
CS 150 A06 A P01	
CS 150 A10 A P01	
CS 150 A25 A P01	

LMP FILTER ELEMENT - LENGTH 5

Inorganic microfibre
CU 400 5 A03 A N P01
CU 400 5 A10 A N P01
CU 400 5 A16 A N P01
CU 400 5 A25 A N P01

WATER REMOVAL - CARTRIDGE EXTENDED LENGTH

Multi-Layer water absorber
CW150P10A

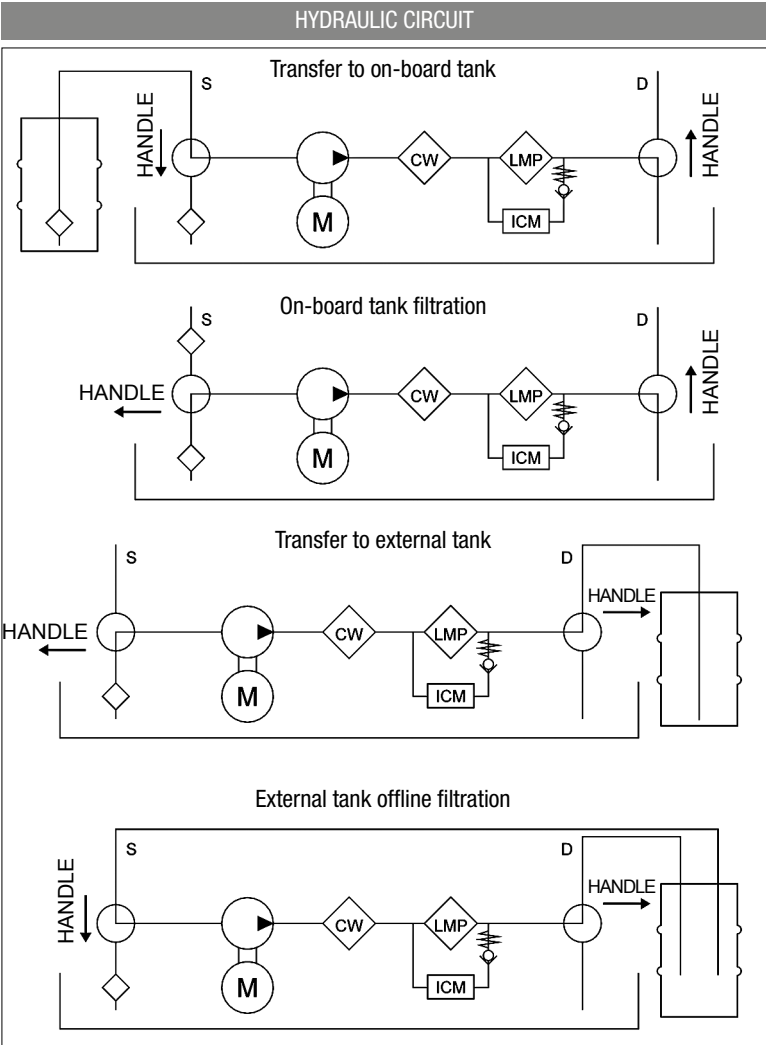
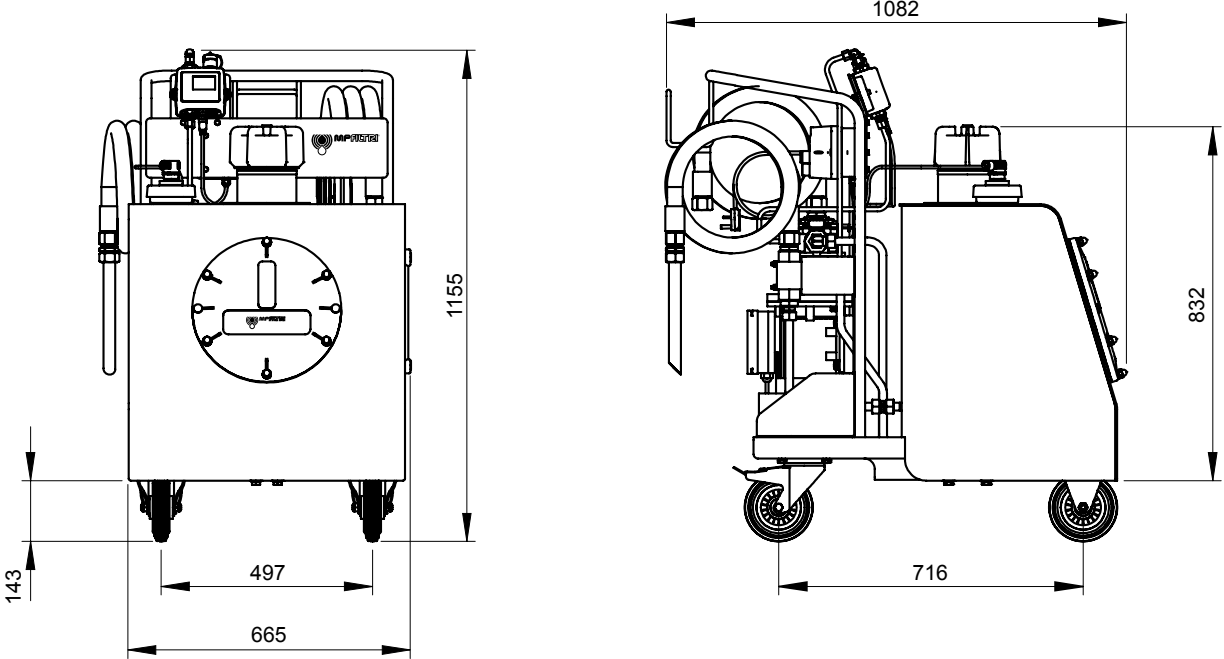



WORLDWIDE NETWORK

HEADQUARTERS

MP Filtri S.p.A.
Pessano con Bornago
Milano - Italy
+39 02 957031
sales@mpfiltri.it

BRANCH OFFICES

ITALFILTRI LLC
Moscow - Russia
+7 (495) 220 94 60
mpfiltrirussia@yahoo.com

MP Filtri Canada Inc.
Concord - Ontario - Canada
+1 905 303 1369
sales@mpfiltricanada.com

MP Filtri France SAS
Villeneuve la Garenne
France
+33 (0)1 40 86 47 00
sales@mpfiltrifrance.com

MP Filtri Germany GmbH
St. Ingbert - Germany
+49 (0) 6894 95652-0
sales@mpfiltri.de

MP Filtri India Pvt. Ltd.
Bangalore - India
+91 80 4147 7444 / +91 80 4146 1444
sales@mpfiltri.co.in

MP Filtri (Shanghai) Co., Ltd.
Shanghai - Minhang District - China
+86 21 58919916 116
sales@mpfiltrishanghai.com

MP Filtri U.K. Ltd.
Bourton on the Water
Gloucestershire - United Kingdom
+44 (0) 1451 822 522
sales@mpfiltri.co.uk

MP Filtri U.S.A. Inc.
Quakertown, PA - U.S.A.
+1 215 529 1300
sales@mpfiltriusa.com

PASSION TO PERFORM



mpfiltri.com